

# Understanding The UL Directory



**National**   
**Gypsum**®

# Fire-Resistance Ratings – ANSI/UL 263

## Design Information Section

### I. INTRODUCTION

This category covers fire-rating certifications based upon the test method and acceptance criteria in ANSI/UL 263 (ASTM E119), “Fire Tests of Building Construction and Materials.” The ratings are expressed in hours and are applicable to floor-ceilings, roof-ceilings, beams, columns, walls and partitions.

The average furnace temperature from which these ratings are derived is 1000°F at 5 min., 1400°F at 15 min., 1550°F at 30 min., 1700°F at 60 min., 1850°F at 120 min., 1925°F at 180 min. and 2000°F at 240 min.

When a test assembly complies with the acceptance criteria, a detailed description of the assembly, its performance in the fire test, and other pertinent details such as specification of materials, certification coverage and alternate assembly details are included in a Report for the test sponsor. Sponsors may provide copies of the complete Test Report upon request. The Report also contains a summary of important features of the rated assembly. These summaries are also published in this Directory. Variations from the published specifications should be considered as not being investigated by UL.

### NUMBERING SYSTEM FOR FIRE-RATED ASSEMBLIES

Types of Protection									
Groups of Construction	Membrane Protection						Direct Applied Protection		Unprotected
	000-099	100-199	200-299	300-399	400-499	500-599	600-699	700-899	900-999
Floors-Ceilings: A or B* Concrete and Cellular Steel Floor C -Glazing Systems	Concealed Grid Sys.	(Reserved)	Exposed Grid System	(Reserved)	Metal Lath	Gypsum Board	Misc.	SFRM+	Unprotected
D, E* or F* Concrete and Steel Floor Units	Concealed Grid Sys.	(Reserved)	Exposed Grid System	Mineral and Fiber Boards	Metal Lath	Gypsum Board	Mastic and Intumescent Coatings	SFRM+	Unprotected
G or H* Concrete and Steel Joists	Concealed Grid Sys.	(Reserved)	Exposed Grid System	Mineral and Fiber Boards	Metal Lath	Gypsum Board	Misc.	SFRM+	Unprotected
I Non-loadbearing Horizontal Barrier	(Reserved)	(Reserved)	(Reserved)	(Reserved)	(Reserved)	Gypsum Board	(Reserved)	(Reserved)	(Reserved)
J or K Concrete	Concealed Grid Sys.	(Reserved)	Exposed Grid System	Mineral and Fiber Boards	Metal Lath	Gypsum Board	Misc.	SFRM+	Unprotected
L or M Wood Joist or Combination Wood and Steel Assemblies	Concealed Grid Sys.	(Reserved)	Exposed Grid System	(Reserved)	Metal Lath	Gypsum Board	Misc.	SFRM+	Unprotected
Beams: N or O* for Floor-Ceiling	Concealed Grid Sys.	(Reserved)	Exposed Grid System	Batts and Blankets or Mineral and Fiber Boards	Metal Lath	Gypsum Board	Mastic and Intumescent Coatings	SFRM+	Unprotected
Roof-Ceiling: P, Q* or R*	Concealed Grid Sys.	(Reserved)	Exposed Grid System	Mineral and Fiber Boards	Metal Lath	Gypsum Board	Misc.	SFRM+	Unprotected
Beams: S or T* for Roof-Ceiling	Building Units	(Reserved)	Exposed Grid System	Mineral and Fiber Boards	Metal Lath	Gypsum Board	Mastic and Intumescent Coatings	SFRM+	Unprotected
Wall and Partition: U, V or W	Building or Partition Panel Units	(Reserved)	Insulating Concrete	Wood Stud, Gypsum Board, Lath &/or Plaster	Metal Stud, Gypsum Board, Lath &/or Plaster	Misc.	Metal Panels, Gypsum Board, Lath &/or Plaster	SFRM+	Masonry
Columns: X, Y or Z*	Building Units	Prefab-ricated	Mat Materials	Batts and Blankets or Mineral and Fiber Boards	Metal Lath & Plaster	Gypsum Board	Mastic and Intumescent Coatings	SFRM+	Masonry

The prefix numbers with an asterisk (\*) and the design numbers indicated as “Reserved” in the above table are for future expansion and to cater to new types of systems developed in the future.

+ SFRM denotes Spray-applied Fire-resistive Materials

Reprinted with permission from UL LLC (pages 1 – 21).

## 1. Rapid-rise Fire Test

Fire-resistance designs for protecting structural members subject to petrochemical exposure fires are investigated according to ANSI/UL 1709, "Rapid Rise Fire Tests of Protection Materials for Structural Steel," and are covered under Fire-resistance Ratings -ANSI/UL 1709 (BYBU). Systems complying with these requirements include an "XR" design prefix.

## 2. Definitions

Definitions of selected terms used to identify the types of protection referenced in the following Numbering System Table are:

**Batts and Blankets** – A category for a group of UL-certified products. The complete description of the products in the category and supplementary requirements for certification are covered under Batts and Blankets (BZJZ).

**Building Units** – A category for a group of UL-certified products. The complete description of the products in the category and supplementary requirements for certification are covered under Building Units (BZXX).

**Concealed Grid System** – Suspension system for acoustical material that is not visible from the occupied space.

**Exposed Grid System** – Suspension system for acoustical material that is visible from the occupied space.

**Fire-resistant Joint System** – An assemblage of specific materials or products rated in accordance with ANSI/UL 2079 to resist, for a prescribed period of time, the passage of fire through joints between fire-resistance-rated assemblies. See Joint Systems (XHBN).

**Insulating Concrete** – Nonstructural concrete with a unit weight less than 60 pcf.

**Membrane Penetration** – An opening made through one side (wall, floor, or ceiling membrane) of a fire-resistance-rated assembly.

**Mineral and Fiber Boards** – A category for a group of UL-certified products. The complete description of the products in the category and supplementary requirements for certification are covered under Mineral and Fiber Boards.

**Miscellaneous (Direct-applied Protection)** – Various types of fire-resistive coating materials, including intumescent mastic and subliming coatings.

**Miscellaneous (Walls and Partitions)** – Various types of wall assemblies, including gypsum wallboard shaft walls, log walls, folding assemblies, and assemblies with glazing materials.

**Partition Panel Units** – A category for a group of UL-certified products. The complete description of the products in the category and supplementary requirements for certification are covered under Units, Partition Panel (CJMR).

**Prefabricated Building Columns** – Structural building columns that include a fire-resistive protection system when delivered to the construction site. These products are certified and identified as Prefabricated Building Columns (CGHT). The complete description of the products and supplementary requirements for certification are covered under CGHT.

**Through Penetration** – An item such as a pipe, cable tray or duct that passes through a horizontal or vertical fire-resistive assembly.

**Through-penetration Firestop Systems** – An assemblage of specific materials rated in accordance with ANSI/UL 1479 (ASTM E814), "Fire Tests of Through-Penetration Firestops." Firestop systems maintain the fire-containment integrity of horizontal or vertical fire-resistive assemblies where through penetrations are located. See Through-penetration Firestop Systems (XHEZ).

**Unprotected Fire-resistive Assemblies** – Assemblies that do not require direct-applied coatings or suspended ceilings to protect the structural elements.

## 3. Numbering System

The summarized form of the test assembly is identified by an alphanumeric design number. The prefix letter designates the group of construction, the first number designates the type of protection, and the other numbers and letters identify the particular assembly.

The prefix letters representing the various groups of constructions are:

Prefix Letters	Group Of Construction
A	Floor-Ceiling Designs - Concrete with Cellular Steel Floor Units and Beam Support
D	Floor-Ceiling Designs - Concrete with Steel Floor Units and Beam Support
G	Floor-Ceiling Designs - Concrete and Steel Joists
I	Non-load-bearing Horizontal Barrier
J or K	Floor-Ceiling Designs - Precast and Field Poured Concrete
L	Floor-Ceiling Designs - Wood or Combination Wood and Steel Joist Assemblies
N	Beam Designs for Floor-Ceiling Assemblies
P	Roof-Ceiling Designs
S	Beam Designs for Roof-Ceiling Assemblies
U or V	Wall and Partition Designs
X or Y	Column Designs

## II. GENERAL

The following information is applicable to all fire-resistive designs described in this Directory. It is recommended that the users review this information in addition to the general guidelines provided for specific materials and construction types.

Authorities having jurisdiction should be consulted before construction.

Fire-resistance ratings apply only to assemblies in their entirety. Except for those separately rated structural members supporting tested assemblies, individual components are not assigned a fire-resistance rating and are not intended to be interchanged between assemblies but rather are designated for use in a specific design in order that the ratings of the

design may be achieved. Unless otherwise specified in the individual design or certification, attachments to structural steel have not been investigated.

All ratings are based on the assumption that the stability of the structural members supporting the assembly is not impaired by the effects of fire. The extent of damage of the test assembly at the rating time is not a criterion for the rating.

The specifications for materials in an assembly are important details in the development of fire-resistance ratings. Those materials provided with an "\*" in the design text are eligible to be produced under the Follow-Up Service Program of UL. Information identifying such materials and the certified companies authorized to provide the materials are located in the product category section of this Directory. The appearance of the UL Certification Mark on the product is the only method provided by UL to identify products that have been produced under its Follow-Up Service.

### **1. Metric Dimensions**

It is recommended that the "Metric Guide for Federal Construction," published by the National Institute of Building Sciences (NIBS), be consulted for guidance regarding the use of metric-dimensioned building materials. The dimensional conversion of building materials from the inch-pound system to metric may either be hard or soft.

Hard conversions are typically applied to manufactured products used in modular construction. These products include suspended ceiling systems, gypsum wallboard, and insulation boards. Certified products which are available in metric sizes are identified in the certification information for the individual product categories located near the end of this Directory.

For soft conversions, inch-pound dimensions are mathematically converted to exact equivalent metric values. Examples of dimensions which may be soft converted include concrete thickness, depth of concealed space above suspended ceilings, and coating thicknesses.

It is recommended that dimensions which are identified as minimum or maximum in fire-resistive designs be initially soft converted and, if required, further converted to a hard metric equivalent following the min/max guidance. The spacing of hanger wire and other supports for suspended ceilings would be examples requiring this type of consideration.

### **2. Loading of Test Specimens**

ANSI/UL 263 requires the load applied to test samples to be based upon the limiting conditions of design as determined by nationally recognized structural design criteria. For some applications, the nationally recognized design criteria may be based upon the Working Stress Design Method or the Limit States Design Method. For applications where these two design methods are available, the load applied to the test sample was determined in accordance with the Working Stress Design Method unless the rated assembly specifically references the Limit States Design Method. Also, unless otherwise stated, the load capacity of steel beams assumes the beams are fabricated from A36 steel.

ANSI/UL 263 permits samples to be tested with the applied load being less than the maximum allowable load

as determined by the limiting conditions of a nationally recognized structural design criteria. The ratings for assemblies determined from tests where the applied load was less than allowed by the nationally recognized structural design criteria are identified as "Restricted Load Condition." The percent of the maximum load, the percent of the maximum stress, and the nationally recognized design criteria are identified in the text describing the structural element of rated assemblies with a restricted load condition. An example of the text used in an assembly with a restricted load condition and steel joist loaded to 80% of the maximum allowable is:

The design load for the structural member described in this design should not: (1) exceed 80% of the maximum allowable load specified in "Catalog of Standard Specifications and Load Tables for Steel Joists and Steel Girders," published by the Steel Joist Institute, or (2) develop a tensile stress greater than 24 ksi, which is 80% of the maximum allowable tensile stress of 30 ksi. (Note: The maximum allowable total load develops a tensile stress of approximately 30 ksi.)

Some restricted-load conditions have resulted from changes in product availability. An example is the substitution of K-Series joists for other series joists as described under **Section III, FLOOR-CEILINGS AND ROOF-CEILINGS, Item 7, Steel Joists.**

Assemblies tested with less than the maximum allowable load that would result from loading calculated using the Limit States Design Method are identified as "Load Restricted." The Percent Load Reduction and corresponding Load Restricted Factor for typical assemblies noted in Table I are based upon loading calculated in accordance with the Working Stress Design Method as compared with loading calculated in accordance with the Limit States Design Method. The calculations were performed for assemblies representing spans and member sizes of typical fire-test assemblies. The loads were calculated assuming a span of 4m for floors and roofs and 3m for walls.

Some fire-resistive designs are specified with a Load Restricted Factor. When using fire-resistive designs with a Load Restricted Factor, the factored resistance of the structural members or components should be reduced by multiplying the factored resistance by the Load Restricted Factor specified in the individual fire-resistive designs.

The Load Restricted Factor should be applied to the factored resistance of all structural members or components, including, but not limited to, factored moment resistance ( $M_r$ ), factored shear resistance ( $V_r$ ), factored tensile resistance ( $T_r$ ), and factored compressive resistance ( $C_r$ ).

**Table 1**

Type Of Assembly	Percent Load Reduction (LSD-WSD) / LSD	Load Restricted Factor
W8x28 -AISC (W200x42 -CISC) noncomposite steel beam	12	0.88
W8x28 -AISC (W200x42 -CISC) composite steel beam	29	0.71
Floor/Roof supported by open-web steel joists	4	0.96
Floor supported by cold-formed steel channels	0	none
Floor supported by 2 x 10 in. (38 x 235 mm) wood joists	35	0.65
Wall supported by 2 x 4 in. (38 x 89 mm) wood studs	18	0.82
Wall supported by cold-formed steel studs	0	none
Steel columns	*	*

The ratings for floors supported by cold-formed steel channels and walls supported by cold-formed steel studs do not have a Load Restriction Factor because the associated loads in Canada and the U.S. are based on the same standard: CSA S136, "North American Specification for the Design of Cold-Formed Steel Structural Members," and "North American Specification and Commentary for the Design of Cold-Formed Steel Structural Members."

\* Unless otherwise specified in the individual designs, columns do not have a Load Restriction Factor, as those ratings are based on temperature limitations in accordance with CAN/ULC-S101.

The engineer of record should be consulted whenever fire-resistive assemblies with Load Restricted Factors are selected. The indicated load reductions are based upon factored load effects that are governed by the reduced factored resistance of the structural elements. The selection of structural elements is, at times, based upon service limits, such as deflection and vibration. These factors and others, such as the change in material strength properties as a function of temperature, should be considered when selecting fire-resistive assemblies with Load Restricted ratings.

Unless stated in a design, it is recommended the Load Restricted Factors in Table I be used.

Assemblies developed from tests where the load applied on the sample was based upon calculations in accordance with the Limit States Design Method are identified in the individual certifications.

**3. Penetrations**

Penetrations through all or a portion of an assembly can significantly affect the rating. Firestop systems developed to protect openings created by penetration items are covered under Through-penetration Firestop Systems ( XHEZ).

**4. Finish Ratings**

A finish rating is established for assemblies containing combustible (wood) supports. The finish rating is defined as the time at which the wood stud or wood joist reaches an average temperature rise of 250°F or an individual temperature rise of 325°F as measured on the plane of the

wood nearest the fire. A finish rating is not intended to represent a rating for a membrane ceiling. The requirements for finish ratings are not included in ANSI/UL 263.

**5. Nails and Screws** \*

**Nails are specified according to ASTM F547, "Standard Terminology of Nails for Use with Wood and Wood-Base Materials," or ASTM C514, "Standard Specification for Nails for the Application of Gypsum Board."**

Nails used to attach gypsum board to wood framing should be cement-coated box nails or cement-coated cooler nails unless specified otherwise in the individual designs.

**Screws meeting ASTM C1002, "Standard Specification for Steel Self-Piercing Tapping Screws for the Application of Gypsum Panel Products or Metal Plaster Bases to Wood Studs or Steel Studs," or ASTM C954, "Standard Specification for Steel Drill Screws for the Application of Gypsum Panel Products or Metal Plaster Bases to Steel Studs from 0.033 in. (0.84 mm) to 0.112 in. (2.84 mm) in Thickness," may be substituted for nails, one for one, when the head diameter, length, and spacing equal or exceed the requirements for the specified nails.** \*

**6. Interior and Exterior Applications**

The fire-resistive designs and UL-certified materials are investigated with the understanding that their use is limited to interior applications unless otherwise specified in the individual designs or certification information (e.g., structural columns "Investigated for Exterior Use"). Where an exterior application of a UL-certified design is desired, the local building code and Authority Having Jurisdiction should be consulted to ensure compliance with other code requirements applicable to exterior use.

**7. Exposed Interior Finishes**

The surface flammability and smoke-development characteristics of certified materials that may be used as exposed interior finishes are measured by the test method in ANSI/UL 723 (ASTM E84), "Test for Surface Burning Characteristics of Building Materials." The flame-spread index of these materials is less than 200, and the smoke-development index of these materials is less than 450. Surface-burning certifications are contained in the Building Materials Directory.

**8. Radiant Heating Cable and Panels**

The effect of the use of electrical radiant heating cable or wire on the fire-resistance performance of assemblies has not been investigated. Unless otherwise specified in the specific design, the use of electrical radiant heating panels in a fire-resistance-rated assembly is not permitted.

**9. Coating Materials**

Coating materials include products identified as: 1) spray-applied fire-resistive materials and 2) mastic and intumescent coatings.

\* **Interpretation of National Gypsum® Company, LLC**

The type of material is specified in each design. Materials that have been investigated for exterior application are so indicated in the individual designs and in the product category.

Regulations governing the application and use of coating materials have been promulgated by many governmental agencies. Authorities Having Jurisdiction should be consulted for current local requirements.

Unless specifically detailed in the individual designs or in the product certification information, the interaction of dissimilar fireproofing materials on the same structural element or at the intersection of structural members, and the adherence of one product to the other, has not been investigated under fire-test conditions.

Unless specifically detailed in the individual designs or in the product certification information, the impact of galvanization applied to structural steel members has not been investigated under fire-test conditions. Galvanization may impact the adhesion of spray applied fire-resistive materials or mastic and intumescent coatings.

### **Spray-applied Fire-resistive Materials**

The surfaces on which the material is to be applied must be free of dirt, oil, and loose scale. Surfaces may be primed with the primers/paints covered under Primers for Structural Steel (CGJM).

The following method of determining the bond strength of the spray-applied materials only applies to primers or paints that are not covered under Primers for Structural Steel (CGJM). Unless specifically prohibited in the individual designs, materials identified as Spray-applied Fire-resistive Materials (CHPX) may be applied to primed or similarly painted wide-flange steel shapes and pipe and tube-shaped columns provided: (A) the beam flange width does not exceed 12 in.; (B) the column flange width does not exceed 16 in.; (C) the beam or column web depth (defined as inside of top flange to inside of bottom flange) does not exceed 16 in.; (D) the pipe outer diameter or tube width does not exceed 12 in.; (E) bond tests conducted in accordance with ASTM E736, "Standard Test Method for Cohesion/Adhesion of Sprayed Fire Resistive Materials Applied to Structural Members," should indicate a minimum average bond strength of 80% and a minimum individual bond strength of 50% when compared with the bond strength of the fire-resistive coating as applied to clean uncoated 1/8-in.-thick steel plate. The average and minimum bond strength values should be determined based upon a minimum of five bond tests conducted in accordance with ASTM E736.

The bond tests need only be conducted when the fire-resistive coating is applied to a primed or similarly painted surface for which acceptable bond strength performance between the primer or other similar material and the fire-resistive coating has not been measured. A bonding agent may be applied to the primed or similarly painted surface to obtain the minimum required bond strength where the bond strengths are found to be below the minimum acceptable values.

As an alternative to the bond test conducted on control samples applied to an uncoated steel plate, the following method may be used for unknown coatings in existing

structures. Sections of painted steel are to be coated with a bonding agent compatible with the sprayed material being used on the project. The treated and untreated substrates should be coated with material, cured, and subjected to five bond tests each, in accordance with ASTM E736. If the failure mode of the sections treated with the bonding agent is 100% cohesive in nature, it will be acceptable to use this bond test value as the control bond strength.

The value obtained on the untreated painted section should be compared with the control value using the minimum 80% average, 50% individual bond strength acceptance criteria established in ASTM E736.

If condition (E) is not met, a mechanical bond may be obtained by wrapping the structural member with expanded metal lath (minimum 1.7 lbs. per sq. yd.).

If any of the conditions specified in (A), (B), (C), or (D) are not met, a mechanical break should be provided. A mechanical break may be provided by mechanically fastening one or more minimum 1.7 lbs. per sq. yd. metal lath strips to the flange, web or tube and pipe surface either by weld, screw, or powder-actuated fasteners, on maximum 12-in. centers, on each longitudinal edge of the strip, so that the clear spans do not exceed the limits established in conditions (A), (B), (C), or (D) as appropriate. No less than 25% of the width of the oversize flange or web element should be covered by the metal lath. No strip of metal lath should be less than 3-1/2 in. wide.

As an alternative to metal lath, the mechanical break may be provided by the use of minimum 12 gauge steel studs with minimum 28 gauge galvanized steel disks if such a system is described in a specific design (usually a bottomless trench in an electrified floor design) for the fire-resistive coating being applied. The studs should be welded to the oversize element in rows such that the maximum clear span conforms to conditions (A), (B), (C), or (D) as appropriate. The spacing of studs along each row should not exceed 24 in., and a minimum one stud per 256 sq. in. should be provided.

Where metal lath strips or steel studs and disks are used, acceptable bond strength as described in item (E) should also be provided. A bonding agent may be applied to the painted surface to obtain the required minimum bond strength where bond strengths to a painted surface are found to be below minimum acceptable values.

The dry density at which sprayed material should be applied to building elements is specified in the individual designs. Dry-density measurements may be determined by removing at least 6-in.-sq. sections randomly selected from the building, subjecting the samples to 120°F in an oven until constant weight is obtained, followed by accurate weighing, measuring and calculation of the density in lbs. per cu. ft. Constant weight is usually obtained after 24 to 48 hours exposure within a 120°F oven.

The spray-applied fire-resistive material thickness specification in a design should be considered the minimum average thickness of the individual thickness readings measured in accordance with ASTM E605, "Standard Test Methods for Thickness and Density of Sprayed Fire Resistive Material Applied to Structural Members." When spray-applied fire-resistive material is applied to metal lath, the

spray-applied fire-resistive material thickness should be measured to the face of the lath unless specified otherwise in the individual designs.

Individual measured thickness, which exceeds the thickness specified in a design by 1/4 in. or more, should be recorded as the thickness specified in the design plus 1/4 in. For design thicknesses 1 in. or greater, the minimum allowable individual thickness should be the design thickness minus 1/4 in. For design thicknesses less than 1 in., the minimum allowable individual thickness should be the design thickness minus 25%.

The thickness of the spray-applied fire-resistive material should be corrected by applying additional material at any location where: (1) the calculated average thickness of the material is less than that required by the design or (2) an individual measured thickness reading is more than 1/4 in. less or more than 25% less (for design thicknesses greater than 1 in. and less than 1 in., respectively) than the specified thickness required by the design.

Areas of the structural frame and/or floor area are to be selected to obtain representative average thicknesses. Thickness readings on the floor or wall area are to be taken symmetrically over the selected area. The average of all measurements is to be considered the average thickness of the area. Thickness measurements on beams and/or columns are to be made around the member at sections within 12 in. of each other. The average thickness is to be considered the average of the readings taken at both sections.

Screw tips penetrating the steel roof deck in all P700 and P800 Series designs require spray-applied fire-resistive material. The spray applied fire-resistive material specified in the design should be applied to cover the tips at a minimum thickness of 1/2 in.

Mixing and spraying instructions are included with each container of material.

### **Mastic and Intumescent Coatings**

The surfaces on which the material is to be applied must be free of dirt, oil, and loose scale. The certification information for materials identified as Mastic and Intumescent Coatings (CDWZ) should be consulted for specific recommendations regarding the application of the coating over primed painted surfaces.

The mastic and intumescent coating thickness specification in a design should be considered the minimum average thickness of the individual thickness readings measured in accordance with Technical Manual 12-B, "Standard Practice of the Testing and Inspection of Field Applied Thin-Film Intumescent Fire Resistive Materials; an Annotated Guide," published by the Association of the Wall and Ceiling Industries.

The mastic and intumescent coating average thickness should not exceed the maximum thickness published in the individual designs and no individual thickness measurement should be less than 80% of the thickness specified in a design.

Mixing and spraying instructions are included with each container of material.

When mastic and intumescent coatings are exposed to fire, they expand and form an insulating char. Unless otherwise detailed in the individual designs, mastic and intumescent coatings are tested without any covering adjacent to the tested member that might interfere with the expansion of the coating. The effect on the fire-resistance rating of steel members (beams, columns, etc.) caused by any covering that would interfere with the expansion of a mastic and intumescent coating during a fire has not been investigated. Contact the manufacturer for their required clearance around structural members protected with mastic and intumescent coatings.

### **10. Gypsum Board**

\*

**Vertically applied gypsum board is gypsum board that is applied with the long edges parallel to the framing members to which it is attached. Horizontally applied gypsum board applied is gypsum board applied with the long edges perpendicular to the framing members to which it is attached.**

**Gypsum board thicknesses specified in specific designs are minimums. Greater thicknesses of gypsum board are permitted as long as the fastener length is increased to provide penetration into framing that is equal to or greater than that achieved with the specified gypsum board thickness and fasteners.**

**Additional layers of gypsum board are permitted to be added to any design.**

**For designs containing the statement, "See Gypsum Board (CKNX) Category for names of Classified Companies," any product in CKNX that meets the specifications described in the individual designs may be used. This statement is applicable to any gypsum board manufacturer who produces certified gypsum board meeting all requirements specified in the individual designs. It is not required that these Design Numbers appear in the individual company's certification found in CKNX.**

### **11. Gypsum Board Joint Treatment (Fire Taping)**

**Unless otherwise specified in the individual designs, all gypsum board systems except those with predecorated or metal-covered surfaces have joints taped and joints and fastener heads covered with one coat of joint compound (fire taped). Base layers in multilayer systems are not required to have joints or fastener heads taped or covered with joint compound.**

### **12. Plaster**

The proper aggregate and mix proportions are specified in each design. Thicknesses are measured from the outer face of the plaster base. When a finish coat is not specified, it is not included in the thickness dimensions, but it may be added. Materials investigated for exterior application are so indicated in the individual designs.

**\* Interpretation of National Gypsum® Company, LLC**

### 13. Dampers

Building codes include requirements for four types of dampers: fire dampers, smoke (leakage-rated) dampers, ceiling dampers, and corridor dampers. Dampers have been investigated for installation in wall or ceiling constructions in the maximum sizes and orientations (vertical or horizontal) indicated in their certification. Dampers have been investigated for the following applications:

**Fire Dampers** (EMME) are intended for use where air ducts and air-transfer openings traverse fire-resistance-rated walls and floors.

**Leakage-rated (Smoke) Dampers** (EMME) are intended for use where air ducts and air-transfer openings traverse smoke barriers.

**Corridor Dampers** (EMME) are intended for use where air ducts penetrate or terminate at horizontal openings in the ceilings of certain corridors, as required by the building code.

**Ceiling Dampers** (CABS) are intended to function as a heat barrier in air-handling openings penetrating fire-resistive membrane ceilings. Additional details on duct outlet protection methods for membrane ceiling constructions, designated Systems A and B, are included under **Section III FLOOR-CEILINGS AND ROOF-CEILINGS, Item 17, Air Ducts and Protection Systems**.

### 14. Wood Structural Panels

Wood structural panel are structural panel products composed primarily of wood and meeting the requirements of U.S. Department of Commerce Voluntary Product Standard PS 1, "Construction and Industrial Plywood," or U.S. Department of Commerce Voluntary Product Standard PS 2, "Performance Standard for Wood-Based Structural-Use Panels." Wood structural panels include all-veneer plywood, composite panels containing a combination of veneer and wood-based material, and mat-formed panels such as oriented strand board and waferboard. The panels bear the label of a code-recognized certification organization with a specific reference to the PS 1 or PS 2 standard. The panels are also marked "Exposure 1" or "Exterior." Some individual designs may limit the type of panel that can be used.

As an alternate, wood structural panels investigated in accordance with APA - The Engineered Wood Association Standard PRP-108, "Performance Standards and Policies for Structural-Use Panels," or PFS Research Foundation Standard PRP-133, "Performance Standards and Policies for Wood-Based Structural-Use Panels," and meeting the description for the panel type in the individual designs, may be used.

### 15. Sound Transmission Class (STC)

In addition to the fire-resistance ratings, where indicated in the individual designs, the Sound Transmission Class (STC) rating is published for those designs where the sound transmission loss (STL) test was also investigated. ASTM E90 (2009), "Standard Test Method for Laboratory Measurement of Airborne Sound Transmission Loss of Building Partitions and Elements," is the test method used to investigate the sound transmission loss for the various designs. The STC rating applies to the assembly of materials as indicated in the individual designs.

### 16. Impact Insulation Class (IIC)

In addition to the fire-resistance ratings, where indicated in the individual designs, the Impact Insulation Class (IIC) rating is published for those designs where the impact noise test was also investigated. ASTM E492 (2009), "Standard Test Method for Laboratory Measurement of Impact Sound Transmission Through Floor-Ceiling Assemblies Using the Tapping Machine," is the test method used to investigate the impact noise of the design. The IIC rating applies to the assembly of materials as indicated in the individual designs.

### 17. Curtain Wall/Floor Protection Systems

Perimeter Fire Containment Systems (XHDG) includes designs that have been investigated to protect the void created at the intersection of a fire-rated floor assembly and an exterior curtain wall assembly.

### 18. Fire-resistant Joint Systems

Joint Systems (XHBN) includes designs that have been investigated to protect the joints between fire-resistance-rated walls, floors, floor-ceiling assemblies, and roof-ceiling assemblies.

### 19. Fire Doors, Frames, and Hardware

See the individual categories under Fire Doors (GSNV) for products associated with fire doors, frames, and associated hardware. This includes leakage-rated products investigated to limit the spread of smoke through these assemblies.

### 20. Glazing, Wired Glass, and Glass Blocks

Fire-protection-rated Glazing Materials (KCMZ) contains information on wired glass and nonwired glazing investigated for fire resistance. Glass Blocks (KCJU) contains information on glass blocks investigated for fire resistance.

## III. FLOOR-CEILINGS AND ROOF-CEILINGS

The following guidelines are directed towards the materials and construction methods described for floor-ceiling and roof-ceiling assemblies. These guidelines are intended to supplement the specific description included with each design.

Specific guidelines for the application of beam designs to floor-ceiling and roof-ceiling assemblies are provided in this Directory under the heading "Beams."

### 1. Concrete

The concrete compressive strength specified in the designs may be reduced 500 psi to obtain the minimum value. The maximum compressive strength is not limited. The thickness is a minimum unless otherwise indicated.

The concrete's air dry unit weight is determined in accordance with ASTM C567, "Standard Test Method for Determining Density of Structural Lightweight Concrete." The unit weight specifications (unless stated as a range for individual designs) have a tolerance of plus or minus 3 pcf. If normal-weight concrete (145 to 155 pcf) is specified, the use of lightweight (90 to 120 pcf) is not recommended because its greater insulating properties could cause higher temperatures on supporting members. When lightweight concrete is specified, the use of normal-weight concrete is not recommended because its lower insulating properties could cause higher unexposed surface temperatures.



## 2. Fiber Reinforcement

Certified synthetic fiber reinforcements may be added to the concrete mix for the purpose of controlling shrinkage cracks.

These fibers are not intended to satisfy any structural requirements. The structural capacity of the concrete slab should be maintained in accordance with the requirements of the ACI building code.

## 3. Steel Floor and Form Units

The type of unit and the minimum steel thickness are specified in each design.

The steel floor and roof deck minimum thickness table is based upon an industry standard for steel deck. The load tables published by the steel deck industry are based upon the design thickness, and a 5% tolerance is applied to derive the minimum thickness. The tolerance is in accordance with American Iron and Steel Institute specifications. For steel floor and roof deck, the minimum bare metal thickness should be as follows:

Gauge	Design Thkns. In.	Min. Thkns. Bare Metal In.
28	0.0149	0.014
26	0.0179	0.017
24	0.0238	0.023
22	0.0295	0.028
20	0.0358	0.034
18	0.0474	0.045
16	0.0598	0.057

The effect on the fire resistance of the assembly when cellular sections are used as air-handling units has not been investigated.

Some steel units are provided with patterned indentations and are thereby considered to act compositely with the concrete topping. Moment and shear capacities are usually determined empirically from structural tests. The allowable load is provided in the manufacturer's catalogs. The loading for floors with noncomposite units (without indentations) is based on their section modulus. Some fire tests have been conducted on slabs utilizing the composite units but with the loading based on the section modulus of the steel. In such cases the design will specify noncomposite loading. Fire tests have generally shown that composite slabs deflect more than similar noncomposite slabs. Therefore, the ratings developed with composite units would not be jeopardized if noncomposite units of the same profile are used provided the loading is based on the section modulus of the noncomposite units.

The steel form units used in floor or roof assemblies may be painted or galvanized when used in designs that include suspended ceilings (Designs G0--, G2--, G4--, G5--, P0--, P2--, P4--, P5--). In designs that specify the steel form units to be welded to supports with welding washers, the welding washers may be omitted when the steel form unit is 22 MSG gauge or heavier.

Normally, assemblies with steel deck are constructed and

tested with simple span conditions; however, the ratings also apply to continuous span conditions.

## 4. Electrical Boxes for Concrete Floors

Outlet Boxes and Fittings Certified for Fire Resistance (CEYY) covers pre-set and post-set inserts for use in concrete floors for electrical and communication connections. These devices have demonstrated an ability to be used in specific assemblies without reducing their fire-resistive ratings. In those floor-ceiling designs where the inserts are not specifically shown, penetrations to the concrete topping with electrical inserts may jeopardize the rating unless proper compensating protection is provided. In the absence of specific information for inserts in the individual designs, inserts that do not penetrate through the entire floor and bear the UL Certification Mark for Outlet Boxes and Fittings Certified for Fire Resistance may be used in floor-ceiling designs which include fire-resistive coating materials on both fluted and cellular floor units for the entire floor span between supports. The cellular units should be protected in one of the following ways:

1. For inserts that penetrate into the top of the cell and where concrete is not removed from the valleys of the steel floor units, the thickness of fireproofing material specified below standard trench headers (with bottom pan) is applicable.
2. For inserts that penetrate into the sides of the cells with no concrete in the valley between the cells under the inserts, the thickness of the fire-resistive coating specified below the bottomless trench header (without bottom pan) is applicable.

The above recommended protection is intended only for structural concrete floors that contain welded wire fabric or fiber reinforcement when permitted and consist of a blend of one or more fluted to one cellular unit. The entire underside of the cellular units should be protected with the same material and thickness as required below the trench headers with a gradual reduction in thickness to that specified for fluted units in the individual designs. The spacing between inserts should be sufficient for structural integrity. The diameter of any holes in the insert cover for the passage of wire should be no more than 1/8 in. larger than the diameter of the wire.

## 5. Nonmetallic Outlet Boxes for Ceilings

Nonmetallic outlet boxes investigated for installation in floor-ceiling or roof-ceiling assemblies are covered under Outlet Boxes and Fittings Certified for Fire Resistance (CEYY).

## 6. Metallic Electrical Outlet Boxes

Certified metallic outlet boxes with metallic or nonmetallic cover plates may be used in floor-ceiling and roof-ceiling assemblies with ratings not exceeding 2 hours. These assemblies should have gypsum wallboard membranes. The metallic outlet boxes should be securely fastened to the joists, and the opening in the wallboard facing should be cut so that the clearance between the box and the gypsum wallboard does not exceed 1/8 in. The surface area of individual boxes should not exceed 16 sq. in. The aggregate surface area of the boxes should not exceed 100 sq. in. per 100 sq. ft. of ceiling surface.

## 7. Steel Joists

The specified minimum-size joist in floor- or roof-ceiling designs is the joist that meets the requirements for both the minimum depth and the minimum weight per foot. Joists that exceed the specified minimum size may be used, provided the accessories are compatible.

The dimension from the bottom chord of joists to the ceiling, whether given or calculated, is a minimum.

Spacing between joists may be increased from that specified to a maximum of 4 ft. on center if the floor slab meets structural requirements and the spacing of the hanger wires supporting the ceiling is not increased. Where it is necessary to provide support for the ceiling hanger wires between the joists, this may be accomplished by using 1-1/2 in., 16 gauge or larger cold-rolled steel channels. Each channel with its web oriented vertically should be placed on top of and perpendicular to the joist's bottom chord and tied thereto with a double strand of 18 SWG galvanized steel wire.

The area of bridging bars or angles specified in the individual designs is a minimum. Larger bridging may be necessary in order to meet the structural and/or code requirements.

For designs requiring application of coating materials to steel joists, the bridging bars or angles should be protected with the coating material thickness required on the joist for a minimum distance of 12 in. beyond the joist.

When the joists are coated with a fire-resistive material, the cavities, if any, between the upper flange of the joist and the steel floor or roof units should be filled with the fire-resistive coating material applied to the joist, unless specified otherwise in the individual designs.

For designs that require the bottom chords of the joists to consist of round bars, the substitution of angles of an equivalent area is not recommended.

K-Series joists, LH-Series joists, and joist girders specified in floor- or roof-ceiling assemblies should be designed and fabricated in accordance with the Steel Joist Institute's Specifications adopted November 4, 1985, and revised May 1, 2000.

K-Series joists may be substituted for other joists specified in floor- or roof-ceiling designs as follows:

### Floor-Ceiling Assemblies

K-Series joists of equal or greater depth and weight per foot may be substituted for any S-, J-, H-, LH- and/or DLH-Series joists in any floor-ceiling design which employs a structural concrete floor and a suspended membrane ceiling.

### Roof-Ceiling Assemblies

K-Series joists of equal or greater depth and weight per foot may be substituted for any S-, J-, H-, LH- and/or DLH-Series joists in any roof-ceiling design, with the following restrictions:

- a) Minimum nominal depth = 10 in.
- b) Maximum tensile stress = 26,000 psi

Any stress limitation specified in floor or roof designs containing S-, J-, H-, LH- and/or DLH-Series joists should remain applicable when a K-Series joist is substituted.

When a K-Series joist is substituted, any restriction regarding

minimum allowable joist member sizes, areas of steel, and/or bridging material sizes remain applicable. Refer to section "Fire-Resistance Ratings with Steel Joists" in the "Standard Specifications Load Tables & Weight Tables for Steel Joists and Joist Girders," 41st edition, published by the Steel Joist Institute, for guidance.

## 8. Precast Concrete Units

For restrained assembly ratings, some designs require end clearances and lateral expansion joints with the use of noncombustible compressible materials along the sides of the precast concrete units. This requirement may be waived and the clearance spaces filled with sand-cement grout if the stiffness of the building floor and supporting column system surrounding the precast concrete units does not exceed 80% of the stiffness of the test frame in which the assemblies are tested and rated.

The relative stiffness of the frame work surrounding a building floor assembly may be calculated using an approximate test frame size of 14 ft. by 17 ft. and an approximate stiffness of frame of 700,000 kip-in. and 850,000 kip-in., expressed by EI/L, along the 17 ft. and 14 ft. dimensions, respectively.

For unrestrained assembly ratings, clearances should be provided around the ends and sides of the precast concrete units so that they may expand freely during fire exposure.

In most floor-ceiling designs, sand-cement grout is required to be poured between adjacent precast units. This grout may be omitted if a minimum 1-in.-thick concrete topping is placed over the precast concrete units.

## 9. Ceiling Control Joints

For G500, L500, and M500-Series floor-ceiling designs having a maximum 1 hr Unrestrained Assembly Rating and having a ceiling membrane consisting of a single layer of nominal 5/8-in.-thick gypsum wallboard, maximum 1/2-in.-wide control joints may be incorporated in the ceiling using one of the following methods:

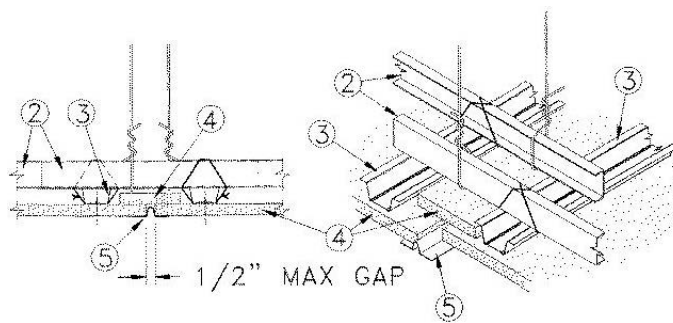

### Ceiling Suspended Below Floor Assembly

**1. Floor Assembly – (Not Shown)** – The floor assembly should be constructed of the materials and in the manner described in the individual G-500, L500, or M500-Series Floor-Ceiling design.

**2. Cold-rolled Steel Channel** – Nom 1-1/2-in.-deep, minimum 16-gauge cold-rolled steel channels installed perpendicular to control joint direction. Channels suspended from floor joists with 12 SWG galvanized steel hanger wires. Hanger wires spaced maximum 48 in. OC. Channels spaced

maximum 24 in. OC. Channels installed to extend approx 6 in. past control joint location with channels on opposite sides of control joint offset from each other. Hanger wire at end of each channel to be located in span between furring channels over control joint location.

**3. Furring Channels** – Nom 7/8 in. deep, minimum 25-gauge painted or galv steel rigid furring channels installed perpendicular to cold-rolled steel channels and spaced maximum 16 in. OC. Furring channel along each side of ceiling control joint to be located with its centerline 3 in. from the center of the control joint. Furring channels secured to cold-rolled steel channels with a double strand of 18 SWG galvanized steel wire.

**4. Gypsum Board** – Installed with long dimension perpendicular to furring channels. Gypsum wallboard type, fastener type and fastener spacings to be as specified in the individual L500-Series Floor-Ceiling design. Maximum width of control joint centered between furring channels is 1/2 in. Strip of gypsum wallboard over control joint to be nom 5/8 in. thick by 3-1/2 in. wide and to be secured to ceiling along only one side of control joint with 1-1/2-in.-long Type G wallboard screws spaced max 24 in. OC.

**5. Control Joint** – Vinyl or zinc control joint conforming to ASTM C1047, "Standard Specification for Accessories for Gypsum Wallboard and Gypsum Veneer Base." Control joint stapled to gypsum wallboard on each side of joint opening prior to finishing of ceiling.

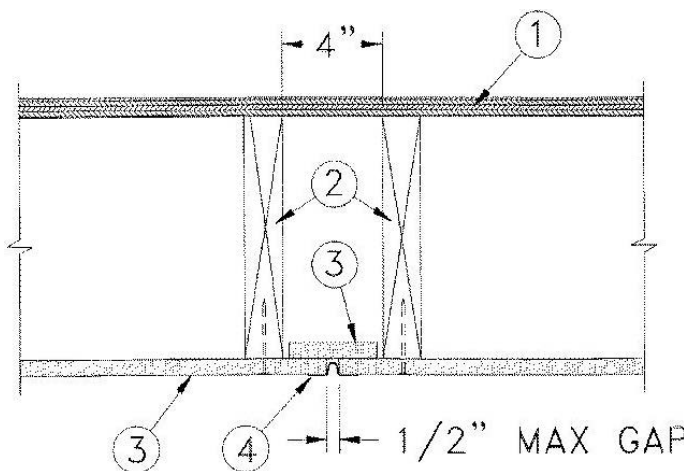

#### Control Joint Parallel With Wood Joists

**1. Flooring** – Lumber or plywood subfloor with finish floor of lumber, plywood, or floor-topping mixture as specified in the individual L500 or M500-Series Floor-Ceiling design.

**2. Wood Joists** – 2 by 10 in., spaced 4 in. apart at the control joint location and maximum 16 in. OC away from control joint as specified in the individual L500 or M500-Series Floor-Ceiling design.

**3. Gypsum Board** – Installed with long dimension perpendicular to wood joists. Gypsum wallboard type, fastener type and fastener spacings to be as specified in the individual L500-Series Floor-Ceiling design. Maximum width of control joint centered between wood joists is 1/2 in. Strip of gypsum wallboard over control joint to be nom 5/8 in. thick by 3-1/2 in. wide and to be secured to ceiling along only one side of control joint with 1-1/2-in.-long Type G wallboard screws spaced max 24 in. OC.

**4. Control Joint** – Vinyl or zinc control joint conforming to ASTM C1047. Control joint stapled to gypsum wallboard on each side of joint opening prior to finishing of ceiling.

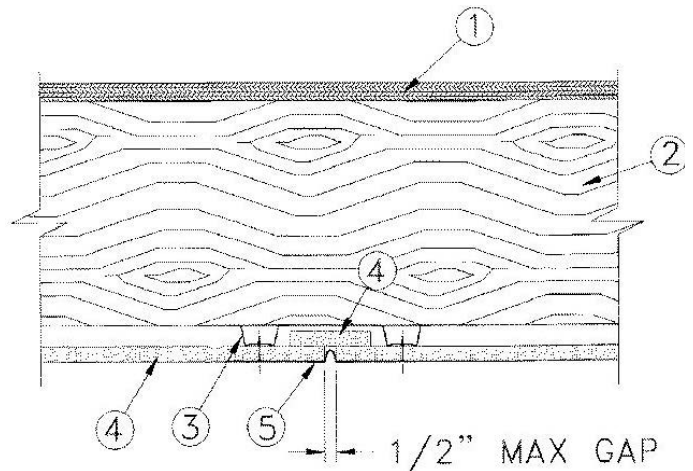

#### Control Joint Perpendicular to Wood Joists

**1. Flooring** – Lumber or plywood subfloor with finish floor of lumber, plywood, or floor-topping mixture as specified in the individual L500 or M500-Series Floor-Ceiling design.

**2. Wood Joists** – 2 by 10 in., spaced maximum 24 in. OC as specified in the individual L500 or M500-Series Floor-Ceiling design.

**3. Furring Channels** – Nom 7/8 in. deep, minimum 25 gauge painted or galvanized steel rigid furring channels installed perpendicular to wood joists and spaced channels maximum 16 in. OC. Furring channel along each side of ceiling control joint to be located with its centerline 3 in. from the center of the control joint. Furring channels secured to wood joists as specified in the individual L500-Series Floor-Ceiling design.

**4. Gypsum Board** – Installed with long dimension perpendicular to furring channels. Gypsum wallboard type, fastener type and fastener spacings to be as specified in the individual L500-Series Floor-Ceiling design. Maximum width of control joint centered between furring channels is 1/2 in. Strip of gypsum wallboard over control joint to be nom 5/8 in. thick by 3-1/2 in. wide and to be secured to ceiling along only one side of control joint with 1-1/2-in.-long Type G wallboard screws spaced maximum 24 in. OC.

**5. Control Joint** – Vinyl or zinc control joint conforming to ASTM C1047. Control joint stapled to gypsum wallboard on each side of joint opening prior to finishing of ceiling.

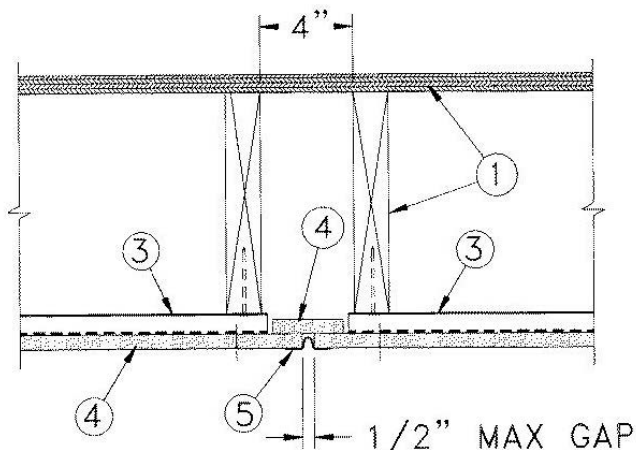

### Control Joint Parallel with Wood Joists

**1. Flooring** – Lumber or plywood subfloor with finish floor of lumber, plywood, or floor-topping mixture as specified in the individual L500 or M500-Series Floor-Ceiling design.

**2. Wood Joists** – 2 by 10 in., spaced maximum 24 in. OC as specified in the individual L500 or M500-Series Floor-Ceiling design.

**3. Furring Channels** – Nom 7/8 in. deep, minimum 25 gauge painted or galvanized steel rigid furring channels installed perpendicular to wood joists and spaced maximum 16 in. OC. Furring channels to cantilever approx 1/4 in. beyond wood joist in 4-in.-wide joint cavity containing control joint. Furring channels secured to wood joists as specified in the individual L500-Series Floor-Ceiling design.

**4. Gypsum Board** – Installed with long dimension perpendicular to furring channels. Gypsum wallboard type, fastener type, and fastener spacing to be as specified in the individual L500-Series Floor-Ceiling design. Maximum width of control joint centered in 4-in.-wide joist cavity is 1/2 in. Strip of gypsum wallboard over control joint to be nom 5/8 in. thick by 3 in. wide and to be secured to ceiling along only one side of control joint with 1-1/2-in.-long Type G wallboard screws spaced max 24 in. OC.

**5. Control Joint** – Vinyl or zinc control joint conforming to ASTM C1047. Control joint stapled to gypsum wallboard on each side of joint opening prior to finishing of ceiling.

### 10. Acoustical Material

The type and size are specified in the individual designs. Where a range of panel sizes is indicated, compatible sizes of suspension members must be used. Designs incorporating lay-in acoustical ceiling panels specify the use of hold-down clips. Hold-down clips are required for assemblies incorporating ceiling panels weighing less than 1 lb. per square foot.

### 11. Suspension Systems

The type and size of the suspension system are specified in the individual designs. Support of the system is an important feature in its performance. Spacing of the supports should not exceed but may be less than specified. When the length of the cross tee between the main runner and the wall molding is 30 in. or longer, each such cross tee should be supported by a hanger wire at midpoint of the tee or at a location nearer the wall unless specified differently in the design.

As an alternate to the wall molding specified in the individual designs, the molding may be an angle fabricated from minimum 0.017-in.-thick steel. Each leg of the angle should be at least 7/8 in. long with a 0.115-in. hemmed edge. The wall molding should be reliably secured to the wall with steel fasteners on maximum 16-in. centers unless specified otherwise in a design.

Cross tees which are parallel and adjacent to walls and are spaced 12 in. or less from the wall should each be supported by a hanger wire at midpoint. These hanger wires are intended to minimize their rotation under fire conditions due to the unbalanced weight of panels on their flanges.

Where a ceiling is supported directly from structural members, it may be lowered and intermediate supports may be used, if necessary, provided they produce an in place stiffness equivalent to that of the originally tested elements. A suggested method for providing an equivalent in-place stiffness is by use of 1-1/2-in. cold-rolled channels made of 16 gauge or heavier painted or galvanized steel, with the web oriented vertically and suspended from the structural members by 12 SWG or heavier galvanized steel wire at a maximum spacing of 48 in. OC. The channels may be oriented parallel or perpendicular to the structural members but should be spaced not more than the spacing of the members.

Where it is necessary to cut away the expansion mechanism of suspension members to fit room dimensions or corridor widths, the member should be installed with a gap of approximately 1/10 in. per foot of length to permit free thermal expansion.

Hanger wires should be installed vertically unless permitted otherwise in a design.

Some floor-ceiling designs with structural concrete topping on steel floor units specify the use of steel hanger clips as an attachment provision for hanger wires. As an alternate to hanger clips, low-velocity, powder-actuated, steel-eye pin fasteners may be used for hanger wire attachment in the floor-ceiling designs. The fasteners should have a minimum 5/32-in. diameter by minimum 7/8-in. long pointed shank with a washer and nominal 7/8 in. long by 7/16 in. wide head containing a rounded slot opening. The fasteners are intended to be secured to concrete in valleys of fluted steel floor units with powder charges sufficient to fully embed the shank portion without shattering the concrete.

### 12. Fluorescent Recessed Luminaires

Luminaires may be installed individually or end to end (in rows). Side-by-side installation has not been investigated.

The spacing of luminaires specified in the individual designs refers to the maximum aggregate area of the luminaires to be used in each 100 square feet of ceiling. Unless specified otherwise, the luminaires are of the fluorescent-lamp type with steel housing and hardware.

Where air-handling-type luminaires were tested, the design may describe the luminaire as air-handling or as provided with slots in the housing. However, since no air movement was employed during the test, the ratings require that air movement be effectively stopped at the start of a fire. Air-handling luminaires may be used in any design that specifies luminaires, provided it is not necessary to alter the enclosure

surrounding the luminaire and that provisions are made for effectively stopping the movement of air at the start of a fire.

In ceilings employing an exposed-grid suspension system, when hanger wire is required at midpoint of the cross tee on each side of luminaires, the wire should be installed with approximately 1/8 in. of slack such that it will not be pulling on the cross tee at room temperature conditions.

### **13. Enclosures for Fluorescent Recessed Luminaires**

Enclosures for luminaires should be spaced away from the top of the luminaire housing as shown in the individual designs. When luminaires are installed end to end, one end piece of the protection material that is part of the enclosure should be placed on top of the adjoining top protection pieces to cover the gap at the junction of the luminaires. Spacers placed on top of the luminaire housing to provide clearance for the protection material should not be located directly over or adjacent to luminaire ballasts. Installation is intended to be in conformance with ANSI/NFPA 70, "National Electrical Code." For lay-in panel ceilings, as an alternate to the spacers cut from ceiling material or mineral wool batts, pieces of ceiling-suspension-system tees may be used to maintain the clearance between the protection material and the top of the luminaire.

### **14. Luminaires Certified for Fire Resistance**

In addition to the luminaires described above, luminaires specifically investigated for installation in floor-ceiling and roof-ceiling designs are covered under Luminaires, Luminaire Assemblies and Luminaire Enclosures Certified for Fire Resistance (CDHW). Refer to the individual CDHW certifications for details on the designs in which the luminaires have been investigated and found acceptable.

### **15. Restrained and Unrestrained Assemblies**

Floor-ceiling and roof-ceiling assemblies include fire-resistance ratings for use in both restrained and unrestrained conditions. It is up to the designer and Authority Having Jurisdiction to determine if an assembly is being used in a restrained or unrestrained application, as required by the building code being enforced. Unrestrained Assembly ratings may be used for floor-ceilings and roof-ceilings designed for either restrained or unrestrained conditions.

The conditions of acceptance in ANSI/UL 263 provide criteria for Restrained Assembly Ratings, Unrestrained Assembly Ratings, Restrained Beam Ratings, and Unrestrained Beam Ratings. Because of their more onerous criteria, Unrestrained Assembly Ratings may be used for floors and roofs designed for either restrained or unrestrained conditions.

Certifications resulting from a tested assembly containing a full representation of a floor or roof construction may include: (1) Restrained Assembly Ratings and (2) Unrestrained Assembly Ratings. Results from the testing of these assemblies are identified as Design Nos. A \_\_\_\_\_, D \_\_\_\_\_, G \_\_\_\_\_, J \_\_\_\_\_, or P \_\_\_\_\_. Tested assemblies supported by beams may also include an Unrestrained Beam Rating but do not include a Restrained Beam Rating. A Restrained Beam Rating is determined only from a test on an assembly with a restrained beam and a partial representation of a floor or roof. Results from tests on this type of assembly are identified as Design Nos. N \_\_\_\_\_ or S \_\_\_\_\_.

### **D900 Series Dual Unrestrained Assembly Ratings**

Two unrestrained assembly ratings are indicated for some D900 Series floor-ceiling designs that include unprotected steel floor units. These unrestrained assembly ratings are influenced by the span of the steel floor units. For the longer rating, the maximum span is the span with which the assembly was tested. This rating is determined by the assembly's structural performance during the fire test. The shorter rating is determined by the steel temperatures measured during the test, and the span is limited only by the manufacturer's loading tables.

### **Restraint Conditions**

Certifications of floor-ceiling and roof-ceiling assemblies and individual beams include restrained and unrestrained ratings. ANSI/UL 263 and, specifically, Appendix C, provides general information with respect to the concept of these classifications.

Appendix C of ANSI/UL 263 defines restraint in buildings as: "Floor-ceiling and roof-ceiling assemblies and individual beams in buildings should be considered restrained when the surrounding or supporting structure is capable of resisting substantial thermal expansion throughout the range of anticipated elevated temperatures. Constructions not complying with this definition are assumed to be free to rotate and expand and should be therefore considered as unrestrained."

The restrained condition in fire tests is defined in Appendix C of ANSI/UL 263 as: "one in which expansion at the supports of a load carrying element resulting from the effects of the fire is resisted by forces external to the element." This definition may not be appropriate for conditions of restraint in actual structures. The standard recognizes that the exercise of engineering judgment is required to determine what constitutes "substantial thermal expansion" when determining the conditions under which the restrained or unrestrained ratings should be used.

Restrained conditions for the fire-test assemblies are provided by constructing floor-, beam-and roof-test assemblies within nominal 14-ft.-by-17-ft. frames of composite steel/concrete cross-sections having an approximate stiffness (EI/L) of 850,000 kip-in. and 700,000 kip-in. along the 14-ft. and 17-ft. sides, respectively. The frame stiffness remains constant throughout the fire test because the test frame is insulated from the fire environment.

When applying the published restrained ratings, it is recognized that the individual responsible for the design of the fire-rated construction may ascertain that a different degree of restraint may be provided to the building assembly during a fire condition than was provided to the test sample during the fire test. Under these conditions, the designer may review the Conditions of Acceptance for restrained and unrestrained assemblies and beams in ANSI/UL 263 for additional guidance when determining whether restrained or unrestrained ratings should be specified.

### **16. Air Ducts and Protection Systems**

For designs employing means for the movement of air, ANSI/NFPA 90A, "Installation of Air-Conditioning and Ventilating

Systems," or appropriate model mechanism code should be consulted.

Unless otherwise specified by the design, the ratings were developed based on fire tests employing no air movement. The ratings, therefore, require that air movement be effectively stopped at the start of a fire.

Unless specified otherwise, the minimum distance between the bottom of the duct and the top of ceiling membrane should not be less than 4 in.; where a greater minimum distance is specified, it may be reduced to 4 in. minimum. For ducts equipped with hinged sheet-steel dampers over duct outlets, unless specified otherwise, the maximum distance between the bottom of the duct and the top of the ceiling should not exceed 8 in. When certified ceiling dampers are used, no limit is required for the maximum distance between the bottom of the duct and the top of the ceiling since fire dampers are installed close to the top of ceiling membrane per installation instructions. Where hinged sheet-steel dampers are specified, they should be equipped with spring catches and corrosion-resistant hinges. Dampers designed to close by gravity should be installed to close in the direction of the air flow. Air diffusers should be of steel and attached to the duct outlet with steel sheet-metal screws. Spacing of screws should be at least three equally spaced for round diffusers and 8 in. OC maximum per side for square diffusers, with no less than one on each side.

Except where noted in the individual designs, the air diffusers used in the test assemblies were of the surface-mounted type which also supported the surrounding acoustical material by a flange at least 1 in. wide. The opening in the ceiling membrane for attachment of the diffuser to the duct outlet should not be more than 1 in. greater than the size of the duct outlet. Lay-in-type diffusers may be used when they are described in the individual designs or in the certification information of Ceiling Air Diffusers (BZZU) for individual companies.

Certified Ceiling Dampers (CABS) may be used in lieu of the hinged-door-type dampers in those designs that employ air ducts with the duct outlet protected with a hinged-door-type damper. The maximum area for individual duct outlets and the total aggregate area of duct outlets per each 100 sq. ft. of the ceiling area are specified in the individual designs and are applicable when the hinged-door-type damper is used. If the certified ceiling damper is also eligible for use in the design, then the maximum size of the duct outlets for the certified ceiling damper would apply. The size of the duct outlets should be no larger than the maximum size of the certified ceiling damper.

Some designs specify a smaller aggregate duct outlet area for each 100 sq. ft. of ceiling area than the maximum size of an individual outlet. In this case, when a certified ceiling damper is used, the allowable outlet area per 100 sq ft of ceiling area should be established on the basis of half the area of the individual maximum size.

When a design requires the use of a covering material around the duct outlet and/or the hinged-door damper, ceramic paper or a material having equivalent thermal properties of the ceramic paper should be used.

Duct outlets should be located in the field of an acoustical

panel; however, where it is necessary to cut a main runner or cross tee, each cut end should be supported by a vertical 12 SWG hanger wire. A 1/2-in. clearance should be maintained between the duct outlet and each cut end of the main runner or cross tee. The duct outlet should be located so that no more than one main runner or cross tee is cut when penetrating the ceiling membrane.

Flexible air ducts may be used with certified air-terminal units designated for use in designs. The flexible air duct should be 6 to 8 in. diameter, Class 0 or Class 1 air connector or air duct, bearing the UL Certification Mark. For assemblies with wood joists ("L" Series designs), air ducts only should be used. The flexible duct should be supported 4 ft. to 6 ft. OC with steel straps and/or 12 SWG steel hanger wire so that no portion of the flexible duct is within 4 in. of the top of the ceiling membrane, except where connected to the air-terminal unit.

The following duct outlet protection may be used as alternate systems. System A may only be used when it is specified in the individual designs. System B may be used in any design that contains a steel duct with the duct outlet protected by a hinged-door damper, for equal or smaller outlet size. The systems have been investigated for their effectiveness in retarding the transfer of heat into the ceiling space, but their ability to retard smoke and other combustion products has not been investigated.

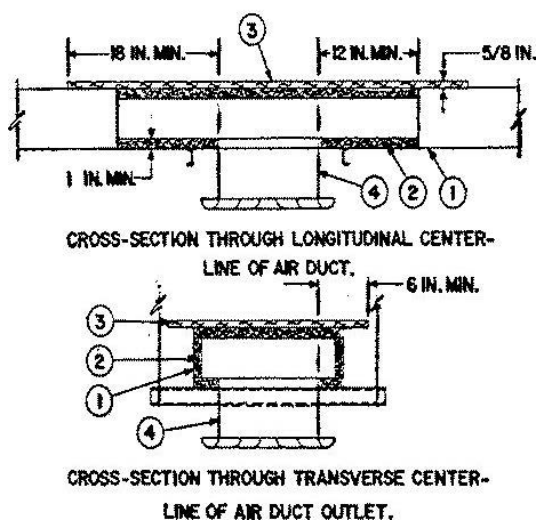

### Duct Outlet Protection System A

**1. Steel Air Duct** – Construction and support provisions are specified by the individual fire-resistance design. Duct outlet to be provided with a louvered, surface-mounted, steel air diffuser, secured with steel fasteners. Duct supported by 1-1/2 in., minimum 0.053-in.-thick (16 gauge) cold-rolled steel channels hung at each end from structural members of floor or roof with 12 SWG galv steel wire. When duct outlets are 144 sq. in. or smaller, cold-rolled channels should be located adjacent to one or both sides of the duct outlet and spaced a max of 48 in. OC. When duct outlets are larger than 144 sq. in., cold-rolled channels should be located adjacent to each side of the duct outlet and spaced a max of 48 in. OC.

**2. Glass Fiber Duct Lining** – Minimum 1-in.-thick, 3.0 to 5.0 pcf density, unfaced or faced with paper, foil, plastic film

or asphalt emulsion. Lining affixed to inside of duct with adhesive or steel fasteners or both. Lining and adhesive should have a flame-spread rating of 25 or less and a smoke-developed index of 50 or less, as determined by ANSI/UL 723 and should comply with all other specifications in ANSI/NFPA 90A. Lining should cover the full inside perimeter of the duct, extending at least 12 in. beyond the edges of the duct outlet. Lining on bottom of duct to be cut flush with the edges of the duct outlet.

**3. Acoustical Lay-in Panel** – Any nom 5/8-in. acoustical lay-in panel certified by UL for use in fire-resistance designs.

Panels should be laid on top of duct, extending at least 6 in. beyond sides of duct outlet along width of duct and extending at least 18 in. beyond sides of duct outlet along length of duct. More than one panel may be butted together to form a panel of the required dimensions. Panels should have a flame-spread index of 25 or less and a smoke developed index of 50 or less as determined by ANSI/UL 723 and should comply with all other specifications in ANSI/NFPA 90A.

**4. Ceramic Paper** – Where specified by the individual fire-resistance design, ceramic paper should be affixed to the duct outlet.

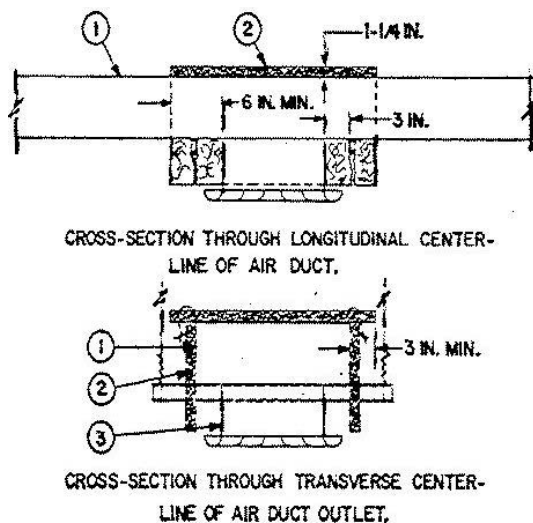

### Duct Outlet Protection System B

**1. Steel Air Duct** – Construction and support provisions as specified in the individual designs. Outlet to be provided with a louvered, surface-mounted, steel diffuser, fastened securely with steel fasteners. Duct supported by 1-1/2-in., minimum 0.053-in.-thick (16 gauge) cold-rolled steel channel hung at each end from structural members of floor or roof with 12 SWG galvanized steel wire. When duct outlets are 144 sq in. or smaller, cold-rolled channels should be located adjacent to one or both sides of the duct outlet and spaced a maximum of 48 in. OC. When duct outlets are larger than 144 sq. in., cold rolled channels should be located adjacent to each side of the duct outlet and spaced a maximum of 48 in. OC.

**2. Mineral Wool Batts** – 1-1/4-in.-thick mineral wool batts, 3.5 to 8.0 pcf density. Top piece of batt should extend at least 3 in. beyond the sides of the duct and 6 in. beyond the edges of the duct outlet. Side pieces should extend from the lower face of the top piece to the upper face of the ceiling membrane along the entire length of the top

piece. Side pieces tied to top piece with 18 SWG galvanized steel wire, 18 in. OC. Material should have a flame-spread index of 25 or less, a smoke-developed index of 50 or less as determined by ANSI/UL 723, and should comply with all other specifications in ANSI/NFPA 90A.

**3. Ceramic Paper** – Where specified in the design, ceramic paper should be affixed to the duct outlet.

### 17. Blanket Insulation \*

**Unless specifically described in the individual designs, the addition of insulation in the concealed space between the ceiling membrane and the floor or roof structure may reduce the hourly rating of an assembly by causing premature disruption of the ceiling membrane and/or higher temperatures on structural components under fire-exposure conditions.**

#### *Insulation in G500, L500, M500 and P500 Series Designs*

**– For 1-hour-rated G500, L500, M500, and P500 Series assemblies, fiberglass insulation, loose-fill, batts, or blankets may be added to the plenum or joist space above the gypsum wallboard, provided an additional layer of gypsum wallboard is added to the assembly.**

The gypsum wallboard should be of the same type as shown in the individual designs. The base layer of wallboard should be attached with the fastener type and spacing as described in the design. It is not necessary to tape the joints of the base layer. The finish layer of gypsum wallboard should also be attached with the fastener type and spacing as described in the individual design. The length of the fasteners should be increased by a minimum of the wallboard thickness of the additional layer. The joints in the finish layer should be finished as described in the design.

Other methods of adding insulation in the plenum or joist cavity are not permitted unless indicated in the individual designs.

### 18. Wood Frame Construction

Spaces between joists or trusses and spaces between the ceiling and the floor above should be provided with fire stopping or draft stopping as specified in the provisions of applicable building codes.

When a non-fire-rated wood stud wall assembly abutts the bottom of a wood joist floor-ceiling assembly employing a membrane ceiling, the membrane should be continuous above the top plate of the wall assembly.

### 19. Roof Coverings

Most roof assemblies are tested with Class C roof covering. The fire-resistance ratings for these assemblies are also applicable when the roof covering is a Class A, B, or C system consisting of hot-mopped or cold-applied bituminous materials. The Class A, B, and C ratings are determined by ANSI/UL 790, "Standard Test Methods for Fire Tests of Roof Coverings."

\* *Interpretation of National Gypsum® Company, LLC*

Class A, B, or C roof coverings consisting of hot-mopped or cold-applied bituminous materials or roof-covering material certified under Roofing Membranes (CHCI) may be applied directly to concrete or wood surface of floor designs being used as roofs without a reduction of fire-resistance ratings.

Class A, B, or C prepared roof coverings may be used on wood floor designs without a reduction of the fire-resistance rating, provided a nailer of equal thickness to the length of the mechanical fasteners is added to the flooring.

## 20. Roof Insulation

Roof insulation should be carefully controlled relative to manufacturer, type, and thickness as specified. Less than the specified thickness could result in higher temperatures on the roof covering, while a greater thickness of insulation could cause earlier structural failure.

Certified polystyrene insulation, with a density of 5 pcf or less, may be placed on concrete floors or structural concrete roofs without reducing the assembly rating.

When mineral and fiber boards, polystyrene insulation exceeding 5 pcf, or polyisocyanurate insulation are used over the concrete in D900 Series designs, the unrestrained beam rating should be increased by a minimum of 1/2 hr.

## 21. Uplift Resistance

The resistance of the roof assemblies to uplift by pressures on the roof surface or other damage that may result from high-velocity wind has not been investigated. Roof deck constructions certified for uplift resistance are illustrated in the Roofing Materials and Systems Directory.

## 22. Steel Roof Deck Fasteners

Steel roof deck fasteners that have been investigated as part of a roof deck construction may be used to fasten the roof deck to steel joists or beams in lieu of welding or screws in fire-resistive assemblies. See Roof Deck Fasteners (TLSX) for a list of manufacturers. See Roof Deck Constructions (TGKX) for a list of roof constructions that have been investigated for uplift resistance. The steel fasteners must be compatible with the construction shown in the individual fire-resistive designs.

Screw tips penetrating the steel roof deck in all P700 and P800 Series designs require spray-applied fire-resistive material. The spray-applied fire-resistive material specified in the design should be applied to cover the tips at a minimum thickness of 1/2 in.

## 23. Steel Floor Unit Fasteners

The connection of the steel floor or roof units to the supporting steel structure is specified in the individual design. For A \_\_\_\_\_, D \_\_\_\_\_, and G \_\_\_\_\_ Series designs requiring puddle welds of the steel floor units to the supporting steel structure, powder-driven fasteners may be used as an alternate to the puddle welds, provided equivalent strength capacity is maintained in the connection.

Minimum 3/4-in.-long #10 self-drilling screws may be used as an alternate to button-punching the side laps of adjacent steel floor and form units in A \_\_\_\_\_, D \_\_\_\_\_, G \_\_\_\_\_, and P \_\_\_\_\_ Series designs. The spacing of the screws should be the same as indicated for the button punches.

## IV. BEAMS

---

This section applies to W-, M- or S-shaped hot-rolled structural steel sections as defined by the American Institute of Steel Construction. Unless otherwise noted in the individual certification or design, castellated beams have not been investigated.

The conditions of acceptance in ANSI/UL 263 provide criteria for Restrained Beam Ratings and Unrestrained Beam Ratings. A greater thickness of protection material is typically required for the Unrestrained Beam Rating as compared with the protection material thickness required for the Restrained Beam Rating based on the differences in the rating criteria. Accordingly, Unrestrained Beam Ratings may be used for beams designed for either restrained or unrestrained conditions. Restrained Beam Ratings may be used for beams designed for restrained conditions.

ANSI/UL 263 provides for beams to be included in two types of test assemblies. One type of test assembly contains a full representation of the floor or roof construction being supported by the beam. Certifications resulting from this type of tested assembly may include: (1) Restrained Assembly Ratings, (2) Unrestrained Assembly Ratings, and (3) Unrestrained Beam Ratings. Restrained Beam Ratings are not determined from this type of test assembly. Results from these tests are identified as Design Series Nos. A00, D00, G00, J00, or P00. The other type of test assembly contains a partial representation of the floor or roof construction. Certifications resulting from this type of tested assembly may include: (1) Restrained Beam Ratings and (2) Unrestrained Beam Ratings. Ratings for floor or roof assemblies are not determined from this type of test assembly. Results from these tests are identified as Design Series Nos. N00 or S00.

### 1. Beam Size

For fire-resistance purposes, the minimum beam size is expressed in terms of a W/D ratio, where W is the weight of the beam per lineal foot and D is the perimeter of protection material at the interface between the steel section and the protection material. Accordingly, beams of the same configuration and having a greater W/D ratio than the beam size specified in the fire-resistive design are considered larger than the specified minimum-size beam and may be used in that design.

W/D values are published by the American Institute of Steel Construction. In 2001, the method used to calculate the perimeter was refined to include the fillets of hot-rolled sections rather than assuming right-angle intersections. An example of this change results in the W/D value for a W8x28 section changing from 0.80 to 0.819.

Application of equations in the Fire-resistance Directory that include proportional relationship of the (W/D) value are not affected by the change in the calculation process for (W/D), provided the (W/D) values used are determined by a single method.

### 2. Composite and Noncomposite Beams

For assemblies that specify both Restrained and Unrestrained Assembly ratings, noncomposite beams may be substituted when composite beams are specified in a design because composite beams deflect more under fire conditions when



loaded to their design load than noncomposite beams. Composite beams may only be substituted into designs which specify composite beams.

### **3. Cavities**

Cavities, if any, between the upper-beam flange and the steel floor or roof units should be filled with the fire-resistive coating material applied to the beam, unless specified otherwise in the individual design.

### **4. Beam Substitution**

Beam ratings depend upon the type of floor or roof the beam is supporting and the protection on the floor or roof units, as well as the type and thickness of protection material applied to the beam. The substitution of beams into a floor assembly (A--, D--, G--or J--Design) or roof assembly (P--Design) should be limited to assemblies that have a similar or greater capacity for heat dissipation from the beam as compared with the capacity for heat dissipation of the floor or roof construction specified in the design from which the beam is being transferred.

For concrete floors, an equal or greater capacity for heat dissipation exists when the concrete has an equal or greater density range and volume per unit of floor area.

#### **Spray-applied Fire-resistive Materials Application of N Series Designs**

When it is the intent to only maintain the existing Assembly Rating, the beams, steel joists, and steel trusses from N Series designs may be substituted for the tested structural member, provided the hourly Unrestrained Beam Rating of the structural member being transferred is at least equal to the Unrestrained Beam Rating of the structural member being replaced. Additionally, for steel joists and steel trusses, the Restrained Beam Rating of the joist or truss being transferred should be equal to or greater than the Restrained Assembly Rating of the floor-ceiling assembly into which the joist or truss is being transferred.

When it is the intent to comply with requirements that the structural member's hourly rating be equal to or greater than the assembly's hourly rating, the structural member from the N Series design may be substituted for the tested structural member, provided also that the hourly Beam Rating of the structural member being transferred is at least equal to the hourly rating of the requirement. Additionally, the Restrained Beam Rating of the structural member being transferred should be equal to or greater than the Restrained Assembly Rating of the floor assembly into which the structural member is being transferred.

For applications where the assembly's hourly rating differs from the structural member rating, particular attention should be paid to the thickness of fire-protection materials applied to the underside of the floor adjacent to the structural member. The thickness of the fire-protection material required within 12 in. beyond the edges of the structural member should be the lesser of the beam protection thickness or the deck protection thickness as required by the N Series design but not less than the thickness of the fire-protection material required by the assembly.

#### **Application of S Series Designs**

When it is the intent to only maintain the existing Assembly Rating, the beams, steel joists, and steel trusses from the S Series designs may be substituted for the tested structural member, provided the hourly Unrestrained Beam Rating of the structural member being transferred is at least equal to the Unrestrained Beam Rating of the structural member being replaced. Additionally, the Restrained Beam Rating of the structural member being transferred should be equal to or greater than the Restrained Assembly Rating of the roof assembly into which the structural member is being transferred.

When it is the intent to comply with requirements that the structural member's hourly rating be equal to or greater than the assembly's hourly rating, the structural member from the S Series design may be substituted for the tested beam, provided also that the hourly Beam Rating of the structural member being transferred is at least equal to the hourly rating of the requirement. Additionally, the Restrained Beam Rating of the structural member being transferred should be equal to or greater than the Restrained Assembly Rating of the roof assembly into which the structural member is being transferred.

For applications where the assembly's hourly rating differs from the structural member rating, particular attention should be paid to the thickness of the fire-protection materials applied to the underside of the roof deck adjacent to the structural member. The thickness of the fire-protection material required within 12 in. beyond the edges of the structural member should be the lesser of the beam protection thickness or the deck protection thickness as required by the S Series design but not less than the thickness of the fire-protection material required by the assembly.

#### **Application of A, D, G, J, and P Series Designs**

When it is the intent to only maintain the existing Assembly Rating, the beams from A, D, G, J, and P Series designs may be substituted for the tested beam, provided that: (1) the Unrestrained Beam Rating of the beam being transferred is equal to or greater than the Unrestrained Beam Rating of the beam being replaced; and (2) the Restrained Assembly Rating of the assembly from which the beam is being transferred is equal to or greater than the Restrained Assembly Rating of the assembly into which the beam is being transferred.

When it is the intent to comply with requirements that the beam's hourly rating be equal to or greater than the assembly's hourly rating, the beams from A, D, G, J, and P Series designs may be substituted for the tested beam, provided also that the hourly Unrestrained Rating of the beam being transferred is at least equal to the hourly rating of the requirement.

#### **Mastic and Intumescent Coatings Application of N Series and S Series Designs**

The beams, steel joists, and steel trusses from N Series designs may be substituted for the tested structural member, provided the hourly Unrestrained Beam Rating of the structural member being transferred is at least equal to the Unrestrained Beam Rating of the structural member being replaced, and the Restrained Beam Rating of the structural member being transferred is equal to or greater than the

Restrained Assembly Rating of the floor-ceiling assembly into which the structural member is being transferred.

### 5. Unprotected Floors and Roofs

The Unrestrained Beam Ratings in the N400, N600, N700, and N800 Series designs with spray-applied fire-protection material on the steel floor decks may be used with unprotected steel floor deck assembly designs (D900 Series) or unprotected precast concrete floors, provided that the beam fire-protection material is oversprayed to the underside of the floor on both sides of the beam for a minimum width of 12 in. beyond the edges of the beam flange. The thickness of the fire-protection material oversprayed to the underside of the floor should be the same as required for the beam. Overspraying is not required when the N Series designs with unprotected steel floor decks are substituted in the D900 Series designs or to support unprotected precast concrete units.

The Unrestrained Beam Ratings in the S400, S600, S700, and S800 Series designs with spray-applied fire-protection material on the steel roof decks may be used with unprotected steel roof deck assembly designs (P9--designs), provided the beam protection material is oversprayed to the underside of the roof on both sides of the beam for a minimum distance of 12 in. beyond the edges of the beam flange. The thickness of fire-protection material oversprayed to the underside of the roof should be the same as required for the beam. Overspraying is not required when the S--designs with unprotected steel roof decks are substituted in the P9--roof designs.

### 6. Adjustment of Thickness of Spray-applied Fire-resistive Materials for Restrained and Unrestrained Beams

Alternate-sized steel beams may be substituted for the given beam in the A700, A800, A900, D700, D800, D900, G700, G800, J700, J800, J900, N700, N800, P700, P800, P900, S700, and S800 Series designs, provided the beams are of the same shape and the thickness of spray-applied fire-resistive material for 1, 1-1/2, 2, 3, and 4 h Restrained and Unrestrained Beam ratings is adjusted in accordance with the following equation:

$$T_1 = \frac{\left( \frac{W_2}{D_2} + 0.6 \right) (T_2)}{\left( \frac{W_1}{D_1} + 0.6 \right)}$$

Where:

T = Thickness (in.) of spray-applied material

W = Weight of beam (lb./ft.)

D = Perimeter of protection, at the interface of the fire-protection material and the steel through which heat is transferred to steel (in.)

Subscript 1 = Refers to alternate beam size and required material thickness

Subscript 2 = Refers to given beam size and material thickness shown in the individual designs

1) W/D values are not less than 0.37

2) T1 values are not less than 3/8 in., and

3) The Unrestrained and Restrained Beam Rating is not less than 1 hr.

The use of this procedure is applicable to the adjustment of spray-applied fire-resistive material thickness on restrained and unrestrained beams having solid web members. It is not applicable to the adjustment of mastic and intumescent coatings on restrained and unrestrained beams.

When used to adjust the material thickness for a restrained beam, the use of this procedure is limited to steel sections classified as compact in accordance with the "Specification for the Design of Structural Steel Buildings," by the American Institute of Steel Construction, Load and Resistance Factor Design (3rd Ed.).

### 7. Restrained and Unrestrained Conditions

Certifications of floor-ceiling and roof-ceiling assemblies and individual beams include restrained and unrestrained ratings. See **Section III FLOOR-CEILINGS AND ROOF-CEILINGS, Item 16 Restrained and Unrestrained Assemblies for additional information on this subject.**

## V. COLUMNS

The minimum column size and configuration of the steel member are specified in the X and Y Series designs. The same hourly rating applies when a steel section with an equal or greater W/D ratio is substituted for the specified column size of the same configuration.

W/D values are published by the American Institute of Steel Construction for contour and box-protection configurations. In 2001, the method used to calculate the contour perimeter was refined to include the rounded fillets of hot-rolled sections rather than assuming right-angle web-flange intersections. An example of this change results in the W/D value for a W10x49 section (with four-side contour protection) changing from 0.83 to 0.84.

Application of equations in the Fire-resistance Directory that include a proportional relationship of the (W/D) value is not affected by the change in the calculation process for (W/D), provided the (W/D) values used in each application are determined consistently by a single method.

The thickness of the coating materials in the X700, X800, and Y700 Series designs required on wide-flange steel sections smaller than specified in a design may be calculated as follows:

$$X_2 = 1.25 (X_1) \left( \frac{W_1}{D_1} \right) \left( \frac{D_2}{W_2} \right)$$

Where:

$x_2$  = Thickness of coating for smaller wide-flange section

$x_1$  = Thickness of coating used on the rated steel section

$W_2$  = Weight per foot of smaller wide-flange section

$W_1$  = Weight per foot of the rated steel section

$D_2$  = Perimeter of smaller steel section at interface with coating

$D_1$  = Perimeter of the rated steel section at interface with coating

Guidance addressing the application of spray-applied fire-resistive materials to primed or similarly painted wide flange steel shapes is provided in the section titled Coating Materials.

The fire-resistive materials applied to the steel sections should be protected from damage.

## VI. WALLS AND PARTITIONS

The ratings for walls and partitions apply when either face of the assembly is exposed to the fire unless indicated otherwise in a specific design. Flashing and corner details may vary from those described in a design provided structural equivalency is maintained and similar materials to those specified in the design are used for supports, fasteners and flashings. Where dynamic movement is specified in Joint Systems (XHBN) that utilizes either U400, V400 or W400 Series fire-resistance-rated wall and partition assemblies, the special features of the walls to accommodate dynamic movement are intended to be as specified in the individual designs under XHBN.

As stated in ANSI/UL 263, the test specimen is to be representative of the construction for which classification is desired as to materials, workmanship, and details such as dimensions of parts, and is to be built under conditions representative of those practically applied in building construction and operation. Accordingly, wall and partition hourly ratings are applicable when walls are constructed in a true vertical position. Unless otherwise noted in an individual design, the performance of angled walls or walls constructed in the horizontal position has not been investigated.

**The hourly rating of a load-bearing assembly also \* applies to the same assembly when it is used as a non-load-bearing assembly.**

**The size of studs is minimum unless otherwise stated in the individual designs.**

**The spacing of studs is a maximum unless otherwise stated in the individual designs.**

**Spacing between parallel rows of studs are minimums unless otherwise stated in the individual designs.**

**Gypsum board thicknesses specified in specific designs are minimums. Greater thicknesses of gypsum board are permitted as long as the fastener length is increased to provide penetration into framing that is equal to or greater than that achieved with the specified gypsum board thickness and fasteners.**

**Additional layers of gypsum board are permitted to be added to any design.**

**Orientation, vertical or horizontal, of the application of gypsum board in walls and partitions is specified in the individual designs.**

Except when gypsum board is allowed to be applied horizontally in the individual wall designs, horizontal butt joints of vertically applied gypsum board should be

backed by the same type studs as specified in the design. Alternatively, minimum 25 gauge steel framing with a minimum attachment face of 1-1/4 in. may be used for the backing. Both edges of the gypsum board forming the horizontal joint should be attached to the backing with the same screws and spacing as specified in the design for the attachment of the gypsum board edges, then finished as specified for the vertical joints.

Horizontal butt joints on opposite sides of the studs in single-layer applications should be staggered a minimum of 12 in. unless otherwise stated in the individual designs. Horizontal butt joints in adjacent layers on the same face of the assembly in multiple-layer applications should be staggered a minimum of 12 in. unless otherwise stated in the individual designs.

### 1. Wood Stud Walls

Walls of combustible construction should be fireblocked between floors, between the top story and the roof or attic, and at certain intervals laterally in accordance with the provisions of the applicable code to prevent the free passage of flames and hot gases.

The hourly fire ratings for load-bearing wood stud walls tested before January 1, 2009, were derived with a superimposed load applied to the wall assembly intended to theoretically develop maximum working stresses not exceeding the design values published in the Supplement to the 1991 Edition of the "National Design Specification" for wood when horizontally braced at mid-height. When horizontal bracing is referenced in the design it is mandatory, unless otherwise stated.

For fire-resistive designs based upon data generated after December 31, 2008, the superimposed load applied to the wall assembly was derived from ASTM D6513, "Standard Practice for Calculating the Superimposed Load on Wood-frame Walls for Standard Fire-Resistance Tests," and includes a reference to the edition of the "National Design Specification" used to calculate the design load, the design method, the limiting design factor, and the percentage of the design load applied to the test sample.

Wood stud walls may contain fire-retardant-treated studs as well as untreated wood studs. The use of fire-retardant-treated plywood (wood structural panels) may be used in designs that contain use of untreated plywood when all other specified attributes are equivalent to the wood structural panel in the design.

### 2. Steel Studs

**The dimensions and gauge of steel studs are minimums.**

The hourly ratings apply when the steel studs are of a heavier gauge and/or larger dimensions than specified in a design. The superimposed load of bearings walls utilizing steel studs should be based on the capacity of the studs as determined by the "North American Specification and Commentary for the Design of Cold-Formed Steel Structural Members" (2007).

\* *Interpretation of National Gypsum® Company, LLC*

Where lateral support of studs (by means of straps, channels or similar steel members) is required in the design, the loads applied to steel studs should be based on the steel-braced design. The loads based on sheathing bracing should not be assumed, unless otherwise stated in the design.

The loads applied to steel studs having a yield stress higher than the stated minimum should be based upon the specified minimum yield stress stated in the design.

Non-load-bearing steel studs are produced in accordance with ASTM C645, "Standard Specification for Nonstructural Steel Framing Members." In accordance with ASTM C645, the minimum flange width should be 1-1/4 in., and the minimum return lip should be 3/16 in. Studs are also produced with steel having a minimum yield strength of 33 ksi.

### 3. Metal Thickness \*

**Unless otherwise indicated in the individual designs, the following minimum metal thickness tables apply where a metal gauge designation is stated.**

Metal gauges are no longer referenced in ASTM Standards. It is still an industry practice to specify steel components by gauge. Because many of the designs contained herein refer to metal gauge, the following information should be used as a guide where field questions occur. The tables shown herein should be used as a reference and the Authority Having Jurisdiction should be consulted if discrepancies exist between these tables and a local code requirement. Due to structural considerations and fire-performance considerations, the minimum thickness tables are different for steel deck (floor or roof), load-bearing studs, and nonload-bearing studs.

The minimum thickness for load-bearing steel studs is based upon ASTM C955 (1996), "Load-Bearing (Transverse and Axial) Steel Studs, Runners (Tracks) and Bracing or Bridging for Screw Application of Gypsum Panel Products and Metal Plaster Bases." The color code denoted by the ASTM Standard is also shown below. For load-bearing steel studs, the minimum bare-metal thickness should be as follows:

Gauge	Color Code	Min. Thkns. Bare Metal In.
20	White	0.0329
18	Yellow	0.0428
16	Green	0.0538
14	Orange	0.0677

For non-load-bearing studs, the minimum thickness is based upon ASTM C645. The color code denoted by the ASTM Standard is also shown below. For non-load-bearing steel studs, the minimum bare-metal thickness should be as follows.

Gauge	Color Code	Min. Thkns. Bare Metal In.
25	None	0.0179
22	Black	0.0269
20	White	0.0329
18	None	0.0428
16	None	0.0538

### 4. Gypsum Board Joint Treatment

The joints in gypsum board applied to wood or steel studs may either be exposed or covered with joint tape and joint compound for that portion of the joint above a suspended ceiling which is part of a fire-resistive floor-ceiling or roof-ceiling assembly.

### 5. Nonmetallic Electrical Outlet Boxes

Outlet Boxes and Fittings Certified for Fire Resistance (CEYY) includes certifications for nonmetallic outlet and switch boxes for use in wall or partition assemblies. The information provided for each certification includes the model numbers for the certified products, a description of the rated assemblies, the spacing limitations for the boxes, and the installation details. Nonmetallic boxes should not be installed on opposite sides of walls or partitions of staggered stud construction unless certified for use in such constructions.

### 6. Metallic Electrical Outlet Boxes

Certified single- and double-gang metallic outlet and switch boxes with metallic or nonmetallic cover plates may be used in bearing and nonbearing wood stud and steel stud walls with ratings not exceeding 2 hr. These walls should have gypsum wallboard facings similar to those shown in Design Nos. U301, U411, and U425. The metallic outlet or switch boxes should be securely fastened to the studs and the opening in the wallboard facing should be cut so that the clearance between the box and the wallboard does not exceed 1/8 in. The surface area of individual metallic outlet or switch boxes should not exceed 16 sq. in. The aggregate surface area of the boxes should not exceed 100 sq. in. per 100 sq. ft. of wall surface. The aggregate surface area of the boxes may be exceeded when Wall-opening Protective Materials (CLIV) are installed according to the requirements of their certification.

Metallic boxes located on opposite sides of walls or partitions should be separated by a minimum horizontal distance of 24 in. This minimum separation distance between metallic boxes may be reduced when Wall-opening Protective Materials (CLIV) are installed according to the requirements of their certification.

Metallic boxes should not be installed on opposite side of walls or partitions of staggered stud construction unless wall-opening protective materials are installed with the metallic boxes in accordance with certification requirements for the protective materials.

\* **Interpretation of National Gypsum® Company, LLC**

## 7. Exterior Walls

The fire-resistive designs and UL-certified materials for walls and partitions are investigated to ANSI/UL 263, which addresses fire-resistive requirements only with the understanding that their use is intended for interior applications. Where an exterior application of a UL-certified wall or partition design is desired, the local building code and Authority Having Jurisdiction should be consulted to ensure compliance with other code requirements applicable to exterior walls.

## 8. Concrete Masonry Units

Unless otherwise indicated in the individual designs, the allowable compressive stress for the concrete masonry units has been determined from the empirical design method for masonry found in the model codes. For assemblies that have been tested at less than 100% of the allowable compressive stress, the design states the maximum allowable compressive stress for the assembly.

## GYPSUM PANEL PRODUCTS FOR USE IN UL CLASSIFIED SYSTEMS

UL Type Designation	Product Name
Type FSW	5/16" Gold Bond® Brand Fire-Shield® Gypsum Board 5/8" Gold Bond® Brand Fire-Shield® Gypsum Board, Type X 5/8" Gold Bond® Brand Fire-Shield® Exterior Soffit Board, Type X 5/8" Gold Bond® Brand Hi Abuse® XP® Fire-Shield® Gypsum Board, Type X 5/8" Gold Bond® Brand Hi-Impact® XP® Fire-Shield® Gypsum Board, Type X 5/8" Gold Bond® Brand Sta-Smooth® Fire-Shield® Gypsum Board, Type X 5/8" Gold Bond® Brand Fire-Shield® Gypsum Sheathing, Type X 5/8" Gold Bond® Brand XP® Fire-Shield® Gypsum Board, Type X 1" Gold Bond® Brand Fire-Shield® Shaftliner®, Type X 1" Gold Bond® Brand Fire-Shield® Shaftliner XP®, Type X
Type FSW-C	1/2" Gold Bond® Brand Fire-Shield C™ Gypsum Board, Type C 1/2" Gold Bond® Brand Sta-Smooth® Fire-Shield C™ Gypsum Board, Type C 5/8" Gold Bond® Brand Fire-Shield C™ Gypsum Board, Type C 5/8" Gold Bond® Brand Sta-Smooth® Fire-Shield C™ Gypsum Board, Type C 5/8" Gold Bond® Brand XP® Fire-Shield C™ Gypsum Board, Type C
Type FSK	5/8" Gold Bond® Brand Kal-Kore® Fire-Shield® Plaster Base, Type X
Type FSK-C	1/2" Gold Bond® Brand Kal-Kore® Fire-Shield C™ Plaster Base, Type C 5/8" Gold Bond® Brand Kal-Kore® Fire-Shield C™ Plaster Base, Type C
Type FSMR-C	1/2" Gold Bond® Brand XP® Fire-Shield C™ Gypsum Board, Type C 5/8" Gold Bond® Brand XP® Fire-Shield C™ Gypsum Board, Type C
Type FSW-G	1/2" Gridstone Brand Ceiling Panels 1/2" Gridstone Brand CleanRoom Ceiling Panels
Type FSW-3	5/8" Gold Bond® Brand XP® Fire-Shield® Gypsum Board, Type X
Type FSW-5	5/8" Gold Bond® Brand Hi-Impact® XP® Fire-Shield® Gypsum Board, Type X 5/8" Gold Bond® Brand Hi Abuse® XP® Fire-Shield® Gypsum Board, Type X
Type FSW-6	5/8" Gold Bond® Brand eXP® Extended Exposure Sheathing, Type X 5/8" Gold Bond® Brand eXP® Interior Extreme® Gypsum Panel, Type X 5/8" Gold Bond® Brand eXP® Fire-Shield® Tile Backer, Type X 5/8" Gold Bond® Brand eXP® Interior Extreme® IR Gypsum Panel, Type X 5/8" Gold Bond® Brand eXP® Interior Extreme® AR Gypsum Panel, Type X
Type FSW-7	1" Gold Bond® Brand eXP® Extended Exposure Shaftliner, Type X
Type FSW-8	5/8" Gold Bond® Brand Fire-Shield® Gypsum Sheathing, Type X
Type eXP-C	1/2" Gold Bond® Brand eXP® Interior Extreme® C Gypsum Panel, Type C 5/8" Gold Bond® Brand eXP® Interior Extreme® C Gypsum Panel, Type C
Type FSL30	5/8" Gold Bond® Brand High Strength Fire-Shield® LITE®30 Gypsum Board
Type FSL	5/8" Gold Bond® Brand High Strength Fire-Shield® LITE® Gypsum Board, Type X
Type SoundBreak XP	5/8" Gold Bond® Brand SoundBreak® XP® Gypsum Board, Type X
Type SoundBreak Gypsum Board	3/4" Gold Bond® Brand SoundBreak Gypsum Board
Type UltraShield	3/4" Gold Bond® Brand UltraShield Gypsum Board 3/4" Gold Bond® Brand UltraShield XP Gypsum Board
Type DEXcell Glass Mat Roof Board	1/4, 1/2, or 5/8" DEXcell Glass Mat Roof Board 1/4, 1/2, or 5/8" DEXcell FA Glass Mat Roof Board





**Corporate Headquarters**

National Gypsum Company  
2001 Rexford Road  
Charlotte, NC 28211  
Phone: (704) 365-7300  
Web: [nationalgypsum.com](http://nationalgypsum.com)

**Technical Information**

Phone: (800) NATIONAL  
(800) 628-4662  
Fax: (800) FAX-NGC1  
(800) 329-6421

